



Epec 2024 Control Module

Technical Document



DOCUMENT VERSION HISTORY

Date	Notes
07.10.2010	Updated sections <i>2.1.2 Codesys 2.3, 6.1 Protection</i> and <i>7.1 Mounting</i> .
02.12.2009	Sections <i>3.8 Specification for Internal Diagnostics, 3.9 Closed Loops Wiring, 3.10 I/O / IEC Map, 4.2 Power Consumption</i> and <i>4.3 Power Supply Pins</i> updated.
01.10.2008	Document and layout updated
07.03.2008	First released version

Epec Oy reserves all rights for improvements without prior notice

TABLE OF CONTENTS

1	GENERAL	4
1.1	<i>Purpose of This Document</i>	4
1.2	<i>About Manufacturer</i>	4
1.3	<i>Epec CAN Module Family</i>	4
1.4	<i>Basic Skills Required</i>	4
1.5	<i>Safety Guidelines</i>	4
1.6	<i>Warranty</i>	5
1.7	<i>Limited Liability</i>	6
1.8	<i>Environmental Statement</i>	6
2	I/O MODULE GENERAL DESCRIPTION	7
2.1	<i>Programming Environment</i>	7
2.1.1	<i>Codesys 2.1</i>	8
2.1.2	<i>Codesys 2.3</i>	8
2.2	<i>CANopen Indexes</i>	8
3	INPUT / OUTPUT SPECIFICATIONS	9
3.1	<i>Configurable I/Os</i>	9
3.2	<i>Digital Input</i>	10
3.3	<i>Current Measuring Feedback</i>	11
3.4	<i>Digital Input / PWM Output / Digital Output</i>	12
3.5	<i>Digital Input / Analog Input</i>	15
3.5.1	<i>Pins X1.12 and X2.12</i>	17
3.6	<i>Digital Input / Digital Output (sinking)</i>	19
3.7	<i>Digital Input / Pulse Input</i>	21
3.8	<i>Specification for Internal Diagnostics</i>	23
3.9	<i>Closed Loops Wiring</i>	23
3.10	<i>I/O / IEC Map</i>	24
3.11	<i>AMPSEAL Connectors</i>	25
3.12	<i>AMPSEAL Cable Dimensions</i>	25
4	POWER SUPPLY	26
4.1	<i>Overvoltage Protection</i>	26
4.2	<i>Power Consumption</i>	26
4.3	<i>Power Supply Pins</i>	26
5	BUS CONNECTION	27
5.1	<i>Bus Connection Pins</i>	27
5.2	<i>CAN Interface</i>	27
6	ENVIRONMENTAL CHARACTERS	28
6.1	<i>Protection</i>	28
6.2	<i>EMC Tests</i>	28
6.3	<i>Environmental Tests</i>	32
7	HOUSING	34
7.1	<i>Mounting</i>	34
7.2	<i>Unit Dimensions</i>	35
8	ADDITIONAL DOCUMENTS	36

Epec Oy reserves all rights for improvements without prior notice

1 GENERAL

1.1 Purpose of This Document

This technical document is meant to be used in system development. This document contains necessary data concerning the module in question, which system designer needs in system development work.

Copying of this document without permission is prohibited. All trademarks mentioned in this document are owned by their manufacturers.

1.2 About Manufacturer

Epec Oy helps its customers to manufacture efficient, safe and environmental friendly mobile working machines and special vehicles which help their customers to maximise their productivity.

Epec is a solution provider specialized in embedded control systems, vehicle computers and information logistics systems for mobile machines. We believe that we know control systems for challenging conditions and we are able to offer a total solution from control units to project services and designing.

1.3 Epec CAN Module Family

Epec CAN Module Family is designed to operate in extreme environments, where vibration, wide temperature changes and moisture are normal conditions. The requirements for the system's reliability and safety have been the key words in module family development. A small and protective module casing keeps inside high performance microcontroller with lots of control capabilities.

1.4 Basic Skills Required

The user of this document must have professional skills on machine controlling, CAN communication, PLCopen programming according to IEC61131-1 and should have skills to use CoDeSys 2.1/2.3 programming environment.

Please refer CoDeSys 2.1/2.3 manual for further information on programming environment and required installations.

Please refer CAN and CANopen documentation from CAN in Automation (CiA) for further information on communication issues.

1.5 Safety Guidelines

The user of this documentation should follow general machine safety guidelines, directives and regulation appropriate to his/her country or market area.

This product does not comply with SIL2 or SIL3 classifications and should not be used in such applications, e.g. lifting people, where SIL 2 or SIL3 are required by directives or other regulations.

Epec Oy reserves all rights for improvements without prior notice

A separate safety analysis is always recommended for the machine and its control system. The features of this product should be well documented in machine and control system documents so that the machine operator has the right information how to operate the machine correctly and safely.

This product is designed to be used only for machine controlling purposes. The manufacturer does not assume any responsibility for this product being fit for any particular application, unless otherwise expressly stated in writing by the manufacturer.

This product complies with those certifications and standards that are listed below. The manufacturer does not guarantee that this product complies any other certification, standard or test than listed below.

This product is not field serviceable, so it should not be opened at any situation.

An external fuse should be installed for the product or the system power supply.

The system should be designed and constructed according to the Epec general mounting and cabling instruction document.

Epec Oy reserves a right to improve its products without a further notice.

1.6 Warranty

The manufacturer does not assume any responsibility for the products being fit for any particular purpose, unless otherwise expressly stated in writing by the manufacturer.

The manufacturer gives the warranty of twelve (12) months to the products and thereto related firmware from commissioning or eighteen (18) months from the date of delivery of the products which ever occurs first

The manufacturer is during the warranty period responsible for defects in the products and thereto related firmware resulting from faults in material, design or workmanship. The manufacturer's only obligation under this warranty is to, at its sole discretion, either to replace the products and/or thereto related firmware or to repair the defective products. The manufacturer shall, at its sole option, repair the products at its manufactory in Seinäjoki, Finland.

The warranty does not cover any costs related to removing or fastening of devices related to the products. Neither does the warranty cover the expenses of sending devices to or from the manufacturer for repairs. The warranty does not cover possible expenses relating to travelling, accommodation, daily benefits, etc. of installers.

The warranty becomes null and void if the buyer and/or a third party alters the products or the firmware in any way or if they are not used in accordance with the Manufacturer's operating instructions.

All claims with respect to defects in the products shall be made to the manufacturer without delay and no later than on the seventh (7th) day after the defect has been or should have been discovered by the buyer. The manufacturer strives to reply to the claim in writing within two (2) weeks from the receipt of the claim. The buyer shall attach to the claim a possible error report or equivalent explanation of the grounds for the claim.

The manufacturer gives no other warranties whatsoever for the products than the warranty set out in this section and thus the warranty given in this section sets forth the warranty given by the manufacturer in its entirety.

Epec Oy reserves all rights for improvements without prior notice

1.7 Limited Liability

The manufacturer shall under no circumstances be liable for loss of production, loss of profit, loss of use or any other consequential damages and/or indirect losses, whatever their cause may be. In case claims based on product liability are brought against the Manufacturer for which claims the manufacturer may be liable, the manufacturer's liability is limited to the extent normally covered under normal product liability insurances.

The buyer shall compensate the manufacturer to the extent that the manufacturer might be liable to pay damages as a result of claims based on product liability according to paragraph above.

1.8 Environmental Statement

The manufacturer uses ISO14001 environmental certified processes and materials to manufacture products. The manufacturer undertakes to arrange for the recycling and scrapping of the products that are returned to the manufacturer by the buyer and/or the products that are received by the Manufacturer in connection with maintenance services performed as a result of that repairing of the products is deemed by the manufacturer to be inappropriate.

The manufacturer will charge a scrapping fee from the buyer according to the manufacturer's price list in force from time to time. No scrapping fee will, however, be charged for products that are received by the manufacturer during the warranty period.

Epec Oy reserves all rights for improvements without prior notice

2 I/O MODULE GENERAL DESCRIPTION

I/O Module is part of the Epec CAN Module Family. I/O Module has large amount of digital and analog inputs and digital outputs. Digital outputs can be configured to be used as digital inputs and vice versa. Module is used in a CAN control module system as a multifunction controller with different kinds of sensors and actuators, such as proportional valves, servo motors, and electro-hydraulic components. This PLCopen programmable (with CoDeSys tool) module can also be used as an independent controller because of digital and analog I/O capabilities. I/O Module has two CAN-busses.

Features

- ISO High Speed CAN1 interface
- ISO High Speed CAN2 interface
- Operating voltage 10 - 30 VDC
- Recommended operating voltage 24 VDC
- Overvoltage protection
- Overheating and short-circuit protection for outputs
- Short-circuit protection for outputs
- Gold plated, locked and sealed connectors:
 - 8-pin AMPSEAL for module connection
 - 3 x 23-pin AMPSEAL for I/O
- Small outline dimensions: 147 x 113 x 46
- Weight 0,7 kg

Applications

- Forest Machines
- Road Maintenance
- Construction Machines
- Crushing Stations
- Industrial Machines
- Agricultural applications
- Automation applications
- Mining Machines

Monitoring Functions

Following issues can be monitored by the application

- Supply voltage
- Firmware/application code corruption
- Module temperature

Software deadlock is monitored by the hardware watchdog that reboots the module automatically after 300 ms software deadlock.

2.1 Programming Environment

This product can be programmed with either CoDeSys 2.1 or CoDeSys 2.3 depending on the module's firmware. If the firmware's runtime is older than 2.1x, the programming environment is CoDeSys 2.1 and if the runtime is 2.3.x or newer the programming environment is CoDeSys 2.3.

The runtime version can be checked from index with a CANopen tool, for example with CANmoon.

Epec Oy reserves all rights for improvements without prior notice

2.1.1 Codesys 2.1

- Flash
 - 248 x 16-bit flash saved parameters (Runtime older than 2.15)
 - 756 x 16-bit flash saved parameters (Runtime 2.15 or newer)
- CAN buses
 - Supported baud rates 20, 50, 100, 125, 250, 500 and 1000 kbit/s.
 - CAN1
 - CANopen
 - CAN2
 - User programmable
 - J1939
- Pulse inputs
 - Maximum pulse input frequency 20 kHz.
 - Joint frequency for all pulse inputs. (e.g. four channel in use --> 5 kHz for each channel.)
- Minimum PWM frequency
 - 40 Hz for 20 MHz module
 - 80 Hz for 40 MHz module

2.1.2 Codesys 2.3

- Flash
 - 6200 bytes flash saved parameters.
 - 10 separately saved sets.
- Maximum code size 256 kb.
- CAN-buses
 - User programmable CAN for all physical CAN-buses
 - Supported baud rates 50, 100, 125, 250, 500 and 1000 kbit/s.
 - Supported protocols
 - CANopen (for all physical buses)
 - J1939 (only for one bus in the same module)
 - ISOBUS (only for one bus in the same module)
- Possible to add external c-programmed library
- Minimum PWM frequency
 - 40 Hz for 20 MHz module
 - 80 Hz for 40 MHz module
- Maximum pulse input frequency 40 kHz. Joint frequency for all pulse inputs. (e.g. four channel in use --> 10 kHz for each channel). Is dependable for the other interrupt load in module (for example heavy CAN-traffic can reduce maximum frequency).

2.2 CANopen Indexes

CANopen communication features can be installed through software, for example NodeIDs and CAN rates. For more information refer to programming manuals.

Epec Oy reserves all rights for improvements without prior notice

3 INPUT / OUTPUT SPECIFICATIONS

I/O module contains inputs and outputs or, in other words, I/O pins of many different types. There are, for example, outputs which source current and outputs which sink current. Furthermore, there are I/O pins which can be used as inputs or as outputs at the control of the application programmer.

3.1 Configurable I/Os

Max Amount	DI	AI		PI	DO		PWM
	Digital Input	Analog Input	Current Measuring Feedback	Pulse Input	Digital Output (sourcing)	Digital Output (sinking)	Pulse Width Modulation Output
4	x						
4			x				
24	x				x		x
8	x	x					
4	x					x	
8	x			x			
52	48	12		8	28		24

The usage of each I/O pin is determined by the application.

Epec Oy reserves all rights for improvements without prior notice

3.2 Digital Input

Pins X1.19, X1.20, X2.19, and X2.20 are ground referenced inputs (**DI**).

Pins are associated with a bit variable in the **IX** area in PLCopen programming environment. The application program will see there a logical zero when the pin is grounded or left open and a logical one when the pin is connected to a positive voltage source.

Electrical Characteristics

Symbol	Parameter	Conditions	Min	Max	Units
R _I	Input Resistance	V _I Greater than 4,3 V (Note 1)	9,0	11	kΩ
		Referenced to 1,3 V; V _I Less than 4,3 V (Note 1)	6,2	7,6	kΩ
V _{IH}	Input High Voltage		4,8	30	V
V _{IL}	Input Low Voltage		-0,5	4,2	V
f _i	Input Frequency	t _C =10 ms (Note 2, 3, 4, 5)		12	Hz
		Variable t _C (Note 2, 3, 5)		1/8t _C	
C _I	Input Capacitance		Typ. 47		nF

Note 1: With input voltages below 4,3 V it seems like the internal input resistance was connected to a 1,3 V voltage source.

Note 2: t_C denotes software cycle time.

Note 3: Violating this rating may lead to system not recognizing all input state transitions.

Note 4: These parameters depend on software cycle time.

Note 5: Applies to inputs used as normal digital input. Violating this rating may lead to application program not noticing all input state transitions.

Connection Principle

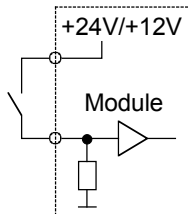

Epec Oy reserves all rights for improvements without prior notice

3.3 Current Measuring Feedback

Pins X1.5, X1.6, X2.3, and X2.4 are normally used as a return path for the loads of PWM outputs. These kinds of pins have a small shunt resistor connected to ground. The shunt resistor is used to measure the current flowing through the load. Nothing prevents using these pins to measure currents from other sources as well.

In PLCopen programming environment, there is a word variable in **IW** area associated with each pin from where the software can read the actual current flowing into the pin.

Electrical Characteristics

Symbol	Parameter	Conditions	Min	Max	Units
R_i	Input Resistance		0,21	0,23	Ω
I_i	Input Current	Analog measuring range	0,0	1,0	A
		(Note 1)		1,7	A
TIRE	Total Input Referred Error			55	mA

Note 1: Exceeding the max value might cause damage to input.

Connection Principle

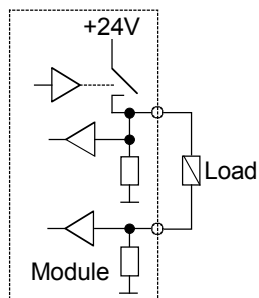

A pin where the upper wire of the load is connected is PWM output / digital output. This illustrates the normal way to connect loads when load current measurement is desired.

Epec Oy reserves all rights for improvements without prior notice

3.4 Digital Input / PWM Output / Digital Output

These pins are current sourcing outputs. In other words, pin connects the load to positive supply voltage. The application program can also simultaneously monitor the actual state of the pin. This feature makes it possible to detect short circuits to the ground. Open loads can not be detected because the internal load resistor is connected to the ground.

Connector X1	Connector X2
X1.1	X2.1
X1.2	X2.2
X1.3	X2.5
X1.4	X2.6
X1.7	X2.7
X1.8	X2.8
X1.14	X2.9
X1.15	X2.10
X1.16	X2.16
X1.17	X2.17
X1.22	X2.22
X1.23	X2.23

These kind of outputs are also capable to generate pulse width modulated (PWM) output signals. This feature is useful when driving proportionally controlled loads, e.g. proportional hydraulic valves. Monitoring the state of the pin is generally not possible when the pin is used as a PWM signal output.

PWM frequencies can be configured under software control in groups of outputs. The frequency is set by **HW_SET_PWM_FREQ** function call. The setting is done by a PWM channel but setting the frequency of one channel sets also the frequencies of all the other channels in the same groups.

In very carefully selected applications a pin of this type can also be used as an input by using the output state monitoring feature. In those cases, the output functionality of the pin must of course be kept in off state. It must be taken care in system design that the output unintentionally switching to on state causes no harm to the system.

Epec Oy reserves all rights for improvements without prior notice

PWM Frequency Control Groups (PFCG)

Group	Channel	Output pin
A	0	X1.23
	1	X1.22
	2	X1.17
	3	X1.16
	4	X1.1
	5	X1.2
	6	X1.4
	7	X1.3
	8	X2.2
	9	X2.1
	10	X2.9
	11	X2.10
B	12	X2.8
C	13	X2.7
D	14	X2.6
E	15	X2.5
F	16	X1.7
	17	X1.8
	18	X1.15
	19	X1.14
	20	X2.17
	21	X2.16
	22	X2.22
	23	X2.23

Electrical Characteristics

Symbol	Parameter	Conditions	Min	Max	Units
R_O	Output Resistance	Output On		0,2	Ω
I_O	Output Current	Output On		3	A
f_{PWM}	PWM Frequency	(Note 1)	80	2550	Hz
	PWM Resolution	Group A and F (Note 1)	5 MHz/ f_{PWM}		
		Group B, C, D and E (Note 1)	625 kHz/ f_{PWM}		
		Group A and F; $f_{PWM}=100$ Hz (Note 1)	50000		
		Group B, C, D and E; $f_{PWM}=100$ Hz (Note 1)	6250		
R_I	Input Resistance	Output Off	2,8	7,5	K Ω
V_{IH}	Input High Voltage		3	V_{IN}	V
V_{IL}	Input Low Voltage	Output Off	-0,5	1	V
f_i	Input frequency	$t_C=10$ ms (Note 2, 3, 4)		12	Hz
		Variable t_C (Note 2, 4)		$1/8t_C$	
t_i	Input Pulse Width	$t_C=10$ ms (Note 2, 3, 4)	40		ms
		Variable t_C (Note 2, 4)	$4t_C$		

Epec Oy reserves all rights for improvements without prior notice

Connection Principle

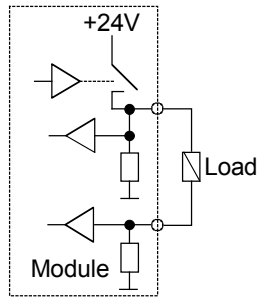

A pin where the lower wire of the load is connected is current measuring feedback. This illustrates the normal way to connect loads when load current measurement is desired.

Connection Principle (when used as an input)

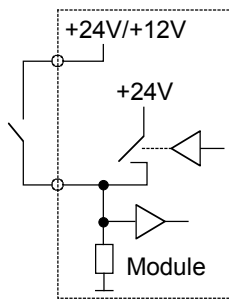

Note 1: PWM capable outputs are divided into six groups. All outputs in the same group share the same PWM frequency (default value 140Hz)

Note 2: Violating this rating may lead to system not recognizing all input state transitions

Note 3: These parameters depend on software cycle time

Note 4: t_c denotes software cycle time

Epec Oy reserves all rights for improvements without prior notice

3.5 Digital Input / Analog Input

Pins X3.5...X3.8, X3.13, and X3.14 are analog inputs. Some of the inputs are grouped: X3.5, X3.6 and X3.7 is defined as group one, and X3.13 and X3.14 is group two. Both groups can be configured either as a current input or as a voltage input. For example, if group two is configured as a current input, then both pins X3.13 and X3.14 can only be used as a current input.

Pins of this kind are used to measure analog signals. They can be used as high impedance voltage inputs for signals from 0 to 5 volts or low impedance current inputs for signals from 0 to 22,7 milliamperes.

Inputs are divided into groups by the input impedance configuration. The input impedance of each group is controlled by a bit in an *Input Impedance Configuration Register (IICR)*. This register is invisible to the programmer but it can be written by **HW_SET_AI_TYPE** function call.



When an input like this is configured as a low impedance current input, it can't withstand the normal maximum input voltage rating. The maximum rating is lowered in this case to 15 volts.

In PLCopen programming environment, there is a word variable in **IW** area associated with each pin from where the software can read the actual signal magnitude at the pin.

In carefully selected applications these pins can also be used as digital inputs. Generally, it is not recommended. In high impedance voltage input configuration they have low threshold voltage which is quite sensitive to interference signals. In low impedance current input configuration they are subject to damage if they are connected to for example 24 volt system voltage. There are bits in **IX** area associated with these inputs to support the DI functionality.

Input Impedance Configuration Register (IICR)

Bit	Input Group
IICR.0	X1.12
IICR.1	X2.12
IICR.2	X3: 5, 6, 7
IICR.3	X3.8
IICR.4	X3: 13, 14

Epec Oy reserves all rights for improvements without prior notice

Electrical Characteristics

Symbol	Parameter	Conditions	Min	Max	Units
V_I	Input Voltage	Analog measuring range	0,0	5,0	V
I_I	Input Current	Analog measuring range	0,0	22,7	mA
V_{IH}	Input High Voltage	(Note 1)	2,0	30	V
		(Note 2)	2,0	15	V
V_{IL}	Input Low Voltage		-0,5	1,0	V
I_{IH}	Input High Current	(Note 2)	9,0	27	mA
I_{IL}	Input Low Current	(Note 2)	0,0	4,5	mA
R_I	Input Resistance	Referred to GND (Note 1)	Typ. 82		k Ω
		(Note 2)	Typ. 220		Ω
TIRE	Total Input Referred Error	(Note 1)		0,25	V
		(Note 2)		1,1	mA
τ_I	Time Constant of Input Low Pass Filter	(Note 1)	3,1	4,7	ms

Connection Principle; High Impedance Voltage Input

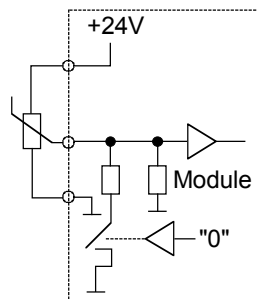

Connection Principle; Low Impedance Current Input

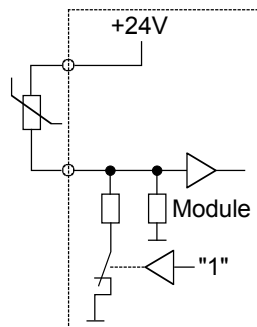

Note 1: Input Configured for Voltage Measurement (220 Ω Input Resistor Disconnected)

Note 2: Input Configured for Current Measurement (220 Ω Input Resistor Connected)

Epec Oy reserves all rights for improvements without prior notice

3.5.1 Pins X1.12 and X2.12

Pins X1.12 and X2.12 are analog inputs.

Pins of this kind are used to measure analog signals. These are intended for use with resistive temperature sensors or other sensors like those. There are an internal 2,2 k Ω resistors connected to +5 V in the module. It provides appropriate measuring current for the external sensor. Any resistive sensor with reasonable resistance range can be used.

They can be used as 2,2 k Ω impedance (to +5 V) voltage input for signals from 0 to 5 volts or low impedance current input for signals from 0 to 22,7 milliamperes.

Normally, low impedance current input should always be kept disconnected. The only reason to connect the resistor would be using the pin as an digital input with current sourcing signal sources (see below).

The connection of the pin resistor is controlled by a bit in *Input Impedance Configuration Register* (IICR). This register is invisible to programmer, but it can be written by **HW_SET_AI_TYPE** function call.



When an input like this is configured as low impedance current input, it can't withstand the normal maximum input voltage rating. The maximum rating is lowered in this case to 15 volts.

In PLCopen programming environment, there is a word variable in **IW** area associated with each pin from where the software can read the actual signal magnitude at the pin.

In carefully selected applications this pin can also be used as digital input. There are bits in **IX** area associated with these inputs to support the DI functionality.

Epec Oy reserves all rights for improvements without prior notice

Electrical Characteristics

Symbol	Parameter	Conditions	Min	Max	Units
V_I	Input Voltage	Analog measuring range	0,0	5,0	V
R_I	Input Resistance	Analog measuring range 1 V...4 V	0,55 ... 8.8		k Ω
I_I	Input Current	Analog measuring range	0,0	22,7	mA
V_{IH}	Input High Voltage	(Note 1)	2,0	30	V
		(Note 2)	2,0	15	V
V_{IL}	Input Low Voltage		-0,5	1,0	V
I_{IH}	Input High Current	(Note 2)	7,5	27	mA
I_{IL}	Input Low Current	(Note 2)	-2,3	2,5	mA
R_I	Input Resistance	Referred to +5 V (Note 1)	Typ. 2.2		k Ω
		(Note 2)	Typ. 220		Ω
IE	Input Error	(Note 2), $I_I = 4$ mA	1,8	2,2	mA
τ_I	Time Constant of Input Low Pass Filter	(Note 1)	50	500	μ s

Connection Principle; Voltage Input

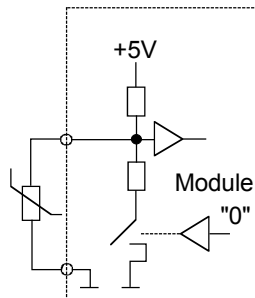

Connection Principle; Low Impedance Current Input

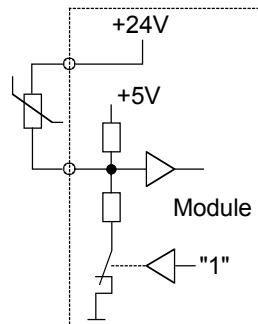

Note 1: Input Configured for Voltage Measurement (220 Ω Input Resistor Disconnected)

Note 2: Input Configured for Current Measurement (220 Ω Input Resistor Connected)

Epec Oy reserves all rights for improvements without prior notice

3.6 Digital Input / Digital Output (sinking)

Pins X1.18, X1.21, X2.18, and X2.21 are current sinking outputs. In other words, pins connect the load to the ground. The application program can also simultaneously monitor the actual state of the pin. This feature makes it possible to detect open loads and short circuits to the supply voltage.

In very carefully selected applications a pin of this type can also be used as an input by using the output state monitoring feature. In those cases, the output functionality of the pin must of course be kept in off state. It must be taken care in system design that the output unintentionally switching to on state causes no harm to system.

There are two bit variables associated with each pin of this type in PLCopen programming environment. The first is one of the **QX** output bits for controlling the pin as an output. The second is one of the **IX** input bits for monitoring the actual state of the output or reading the pin as an input.

Electrical Characteristics

Symbol	Parameter	Conditions	Min	Max	Units
R_O	Output Resistance	Output On		0,12	Ω
I_O	Output Current	Output On		3	A
R_I	Input Resistance	Output Off	9	11	$k\Omega$
V_{IH}	Input High Voltage	Output Off	3,0	30	V
V_{IL}	Input Low Voltage		-0,5	1,0	V
f_i	Input frequency	$t_C=10$ ms (Note 1, 2, 3)		12	Hz
		Variable t_C (Note 1, 3)		$1/8t_C$	
t_i	Input Pulse Width	$t_C=10$ ms (Note 1, 2, 3)	40		ms
		Variable t_C (Note 1, 3)	$4t_C$		

Connection Principle

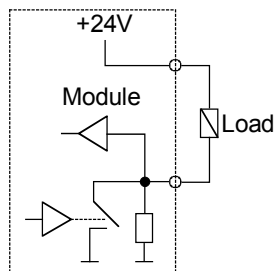

Epec Oy reserves all rights for improvements without prior notice

Connection Principle (when used as input)

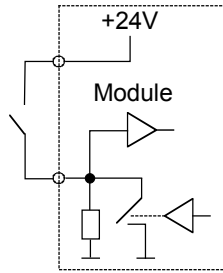

Note 1: Violating this rating may lead to system not recognizing all input state transitions

Note 2: These parameters depend on software cycle time

Note 3: t_c denotes software cycle time

Epec Oy reserves all rights for improvements without prior notice

3.7 Digital Input / Pulse Input

Pins X3.16...X3.23 are ground referenced inputs (**DI**) including pulse counting (**PI**) feature. These pins have 10kΩ resistor connected to GND.

The application program is provided with frequency and number of the pulses seen in the input in addition to the normal input state.

There are three variables associated with each pin of this type in IEC programming environment. The first is a bit variable in the **IX** area just in the same way as with the pins without the **PI** features. The other two are word variables in the **IW** memory area which hold the frequency value and the number of pulses.

After starting up the module measures only the pulse frequency. Pulse counting, if needed, must be enabled explicitly by the application program.

The pulse counting competes with the application program and other processes for the CPU time. This makes it rather hard to estimate the actual maximum frequency of the pulses that the module is able to count reliably. The maximum frequencies given in the table below are such frequencies which make the module to freeze in practice if all inputs are connected to their maximum frequencies. It means that to be able to reach the maximum frequencies, there is no room for application program or any other processes like CAN traffic. So, the practical limits are lower but the maximum values of the table still give the basis for the estimation.

Inputs of this type are also suitable for quadrature sensor position counting. Any of these inputs can be logically paired with another similar input. The result is a two channel pulse counter which is capable of detecting the direction of the movement of the sensor. The pairing is done in application program.

The pulse count and pulse frequency can be read from the pulse input channels. The following table shows the IW-addresses where to read the wanted data (when using CoDeSys 2.1).

Pulse Input channels

Channel	Pin	Pulse Frequency	Pulse Count
0	X3.23	%IW150	%IW160
1	X3.17	%IW151	%IW161
2	X3.16	%IW152	%IW162
3	X3.20	%IW153	%IW163
4	X3.19	%IW154	%IW164
5	X3.18	%IW155	%IW165
6	X3.22	%IW156	%IW166
7	X3.21	%IW157	%IW167

For more information on pulse input channels refer to Hardware Library manual (HW lib).

Epec Oy reserves all rights for improvements without prior notice

Electrical Characteristics

Symbol	Parameter	Conditions	Min	Max	Units
R _i	Input Resistance	V _i greater than 4,3 V (Note 1)	9,0	11	kΩ
		Referenced to 1,3 V; V _i less than 4.3 V (Note 1)	6,2	7,6	kΩ
V _{IH}	Input High Voltage		4,8	30	V
V _{IL}	Input Low Voltage		-0,5	4,2	V
f _i	Input Frequency (frequency measurement and pulse counting)	(Note 2, 3, 6)		5	kHz
		Sum of the frequencies of all the pins (Note 2, 3, 6)		40	kHz
	Input Frequency (normal inputs)	t _C =10 ms (Note 3, 4, 5, 7) Variable t _C (Note 3, 5, 7)		12	Hz
t _i	Input Pulse Width	Note 3, 6	50		μs
		t _C =10 ms (Note 3, 4, 5, 7)	40		ms
		Variable t _C (Note 3, 5, 7)	4t _C		
C _i	Input Capacitance	Pins X3.20-23	Typ. 47		nF
		Pins X3.16-19	Typ. 1		

Connection Principle

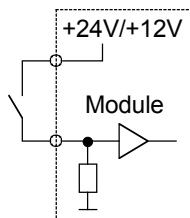

Note 1: With input voltages below 4,3 V it seems like the internal input resistance was connected to a 1,3 V voltage source

Note 2: All conditions must be respected. Even if some of the inputs were not used for frequency measurement or pulse counting, these conditions must nevertheless be respected regarding those inputs too. Otherwise operation of other inputs may be interfered

Note 3: Violating this rating may lead to system not recognizing all input state transitions

Note 4: These parameters depend on software cycle time

Note 5: t_C denotes software cycle time

Note 6: Applies to inputs used for frequency measurement and pulse counting. Violating this rating may lead to incorrect measurement or counting

Note 7: Applies to inputs used as normal digital inputs. Violating this rating may lead to application program not noticing all input state transitions

Epec Oy reserves all rights for improvements without prior notice

3.8 Specification for Internal Diagnostics

This module's internal temperature and incoming operating voltage can be read from the IEC addresses with the numerical values and resolutions shown in the following table.

Type	IEC address	Precision FS	Resolution bits	Full reading	Notes
AI(+5 V)	IW112	$\leq \pm 5,0\%$	10	5 V	
AI(+12 V)	IW113	$\leq \pm 5,0\%$	10	23,5 V	
AI(Vsupply)	IW114	$\leq \pm 5,0\%$	10	46 V	
AI(TEMP)	IW115	$\leq \pm 5,0\%$	10	5 V	TEMP (°C) = (IW115-5177) / 81,3

3.9 Closed Loops Wiring

It is strongly recommended to use closed loops for connecting all sensors, actuators etc. devices to I/O modules. Closed loops wiring can be achieved by connecting the GND wire from the sensor, actuator etc. device into the GND pin of module connector. If it is not possible to use closed loops, use DI/PI pins or DI/AI pins instead.

Epec Oy reserves all rights for improvements without prior notice

3.10 I/O / IEC Map

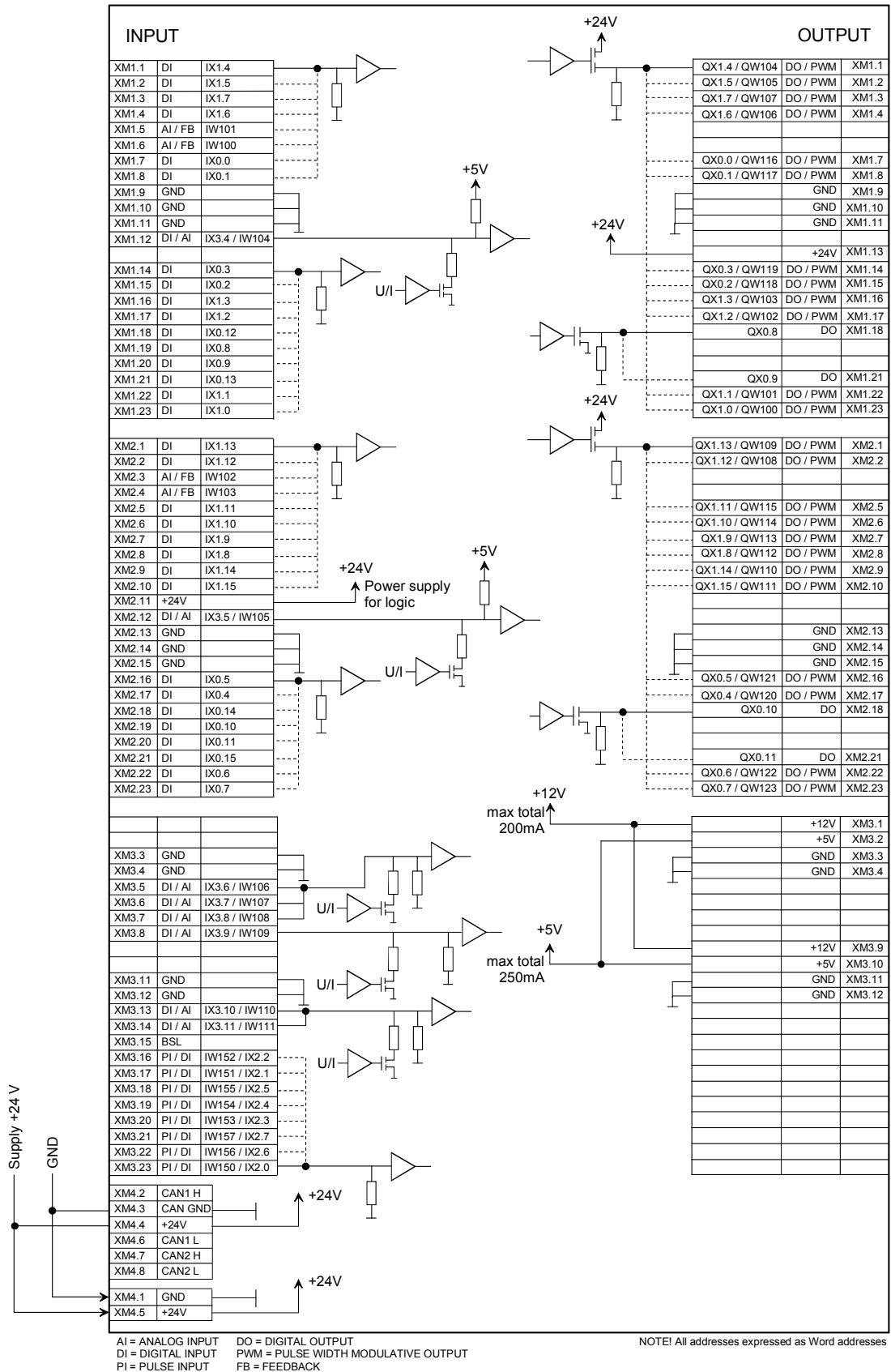

Epec Oy reserves all rights for improvements without prior notice

3.11 AMPSEAL Connectors

Epec uses gold plated, locked and sealed AMPSEAL heavy duty connectors for all Epec CAN Module Family products to ensure the endurance of extreme conditions.

- 8-pin AMPSEAL for power and system CAN connections
- 3 x 23-pin AMPSEAL for I/O
- All connectors are mechanically keyed to mate only with identical colors

AMPSEAL connectors	Epec ordering code
AMP 23-pin grey plug (female)	KX0007
AMP 23-pin black plug (female)	KX0008
AMP 23-pin blue plug (female)	KX0009
AMP 8-pin black plug (female)	KX0187

3.12 AMPSEAL Cable Dimensions

Size		Insulation diameter range	Strip length $\pm 0,4$
mm²	AWG		
0,5	20	1,7	5,1
0,8	18	to	5,1
1,4	16	2,7	5,1
Typical hand crimping tool e.g.:			AMP Procrimper 58529-1, Epec ordering code TT0018

- All applied cables should be properly shielded, bundled and grounded
- See the General Mounting and Cabling Instructions for Epec Modules for more detailed information about the cabling

Epec Oy reserves all rights for improvements without prior notice

4 POWER SUPPLY

- Nominal supply voltage 24 VDC
- Full operating range 10...30 VDC
- No saving operations (program flashing or parameter storing) into permanent memory can be done under 11,5 VDC.
- Undervoltage reset $\leq 9,5$ VDC

4.1 Overvoltage Protection

- Max. 70 VDC (Stresses above this value may cause permanent damage to the module.)
- Module has a shutdown circuit which protects the module and loads against overvoltage. The shutdown circuit cuts off the power feed for the logic and loads in case of overvoltage. The shutdown circuit is activated when voltage reaches circa 32 V. Power feed is restored when supply voltage drops to 30 V.

4.2 Power Consumption

- Approx. 1,8 W (+24 VDC, no external load)
- Supply Voltage (V_{SUPPLY}) maximum continuous current 13 A (with full external load)
- GND current sum max 13 A

4.3 Power Supply Pins

<i>Designation</i>	<i>Connector / pin number</i>	<i>Potential</i>
Supply voltage	X4.4 X4.5	+24 VDC (+10...30 VDC)
Ground (for supply voltage)	X4.1 X4.3	GND
Optional back-up supply voltage for CPU *	X2.11	+24 VDC
Auxiliary supply for external devices	X1.13	V_{SUPPLY} / max 3 A
Internally regulated and monitored auxiliary supply for external devices	X3.1 X3.9	+12 VDC / max 200 mA (max total for all pins together)
Internally regulated and monitored auxiliary supply for external devices	X3.2 X3.10	+5 VDC / max 250 mA (max total for all pins together)
Ground	X1.9 X1.10 X1.11 X2.13 X2.14 X2.15 X3.3 X3.4 X3.11 X3.12	GND (3 A/pin)

* This pin does not provide power supply for current sourcing outputs. Please consult manufacturer before using this pin as a module voltage supply.

Epec Oy reserves all rights for improvements without prior notice

5 BUS CONNECTION

5.1 Bus Connection Pins

The CAN communication pins and the power supply are connected in the module's AMP8 connector as follows:

Designation	Connector / pin number
CAN1 interface, system interface	X4.2 (CAN H) X4.6 (CAN L)
CAN2 interface, user programmable communication	X4.7 (CAN H) X4.8 (CAN L)
Factory use only, this pin must be left open	X3.15

5.2 CAN Interface

Higher layer protocol is user programmable (CAN2) communication. The physical interface of CAN interface is according to ISO 11898 and CAN 2.0B protocol. The downloading of the application programs can only be done via CAN1.

The programmability of CANs depends on the used programming environment as described in the following table:

Programming environment	CAN programmability
CoDeSys 2.1	<ul style="list-style-type: none"> • CAN1 is CANopen compatible • CAN2 is user programmable • CANopen is not available for CAN2
CoDeSys 2.3	<ul style="list-style-type: none"> • CAN1 and CAN2 are CANopen compatible and user programmable • For example CANopen, SAE J1939 or ISOBUS are available for both CANs.

Epec Oy reserves all rights for improvements without prior notice

6 ENVIRONMENTAL CHARACTERS

Epec CAN module family is designed for extreme environments and the product family is certified with normal automotive (e17) EMC standards and has shock and vibration endurance up to 100 G.

- Operating temperature -40°C ... +70°C
- Storage temperature -50°C ... +85°C

6.1 Protection

- IP67 (classification according to IEC 60529)
- Module is equipped with Oil Rating 7 (according to test method AATCC 118-1997ASTM) hydrophobic and oleophobic Gore HPM Membrane Vent
- Protection for plugs depends on cable processing
- All cables, connectors and tools must be of correct type and sufficiently high quality. Also the environmental suitability of equipment should be checked (protection for moisture, mechanical stability, power durability, coupling resistance, among other things)
- Additional module cover for wires and connectors is also available

6.2 EMC Tests

Epec 4G modules are certified according to following tests:

ISO/DIS 14982 (1998) Agricultural and forestry machines-electromagnetic compatibility-test methods and acceptance criteria							
Electrostatic discharge (ESD) immunity test	<ul style="list-style-type: none"> • Test method EN61000-4-2 (1995) • Performance criterion B <table border="1"> <thead> <tr> <th>Discharge mode</th> <th>Test level (kVp)</th> </tr> </thead> <tbody> <tr> <td>Contact</td> <td>± 2, ± 4, ± 6</td> </tr> <tr> <td>Air</td> <td>± 2, ± 4, ± 8</td> </tr> </tbody> </table>	Discharge mode	Test level (kVp)	Contact	± 2, ± 4, ± 6	Air	± 2, ± 4, ± 8
Discharge mode	Test level (kVp)						
Contact	± 2, ± 4, ± 6						
Air	± 2, ± 4, ± 8						
Transient and surges in vehicular environment immunity test Note: The Mini module (2038) and the Mini display (2029) need the Hub module (2021) in order to have the full transient immunity.	<ul style="list-style-type: none"> • Test method ISO 7637-2 (1990), pulse 5 • Performance criterion B <table border="1"> <thead> <tr> <th>Pulse</th> <th>Pulse parameters</th> </tr> </thead> <tbody> <tr> <td>5</td> <td>Us=+70V, tr=10ms, td=600ms</td> </tr> </tbody> </table>	Pulse	Pulse parameters	5	Us=+70V, tr=10ms, td=600ms		
Pulse	Pulse parameters						
5	Us=+70V, tr=10ms, td=600ms						
Commission directive 72/245/EEC, as last amended by commission directive 2006/28/EC Requirements to be met by vehicles and electrical/electronic sub-assemblies fitted to a vehicle							

Epec Oy reserves all rights for improvements without prior notice

<p>Radiated disturbance emission test</p>	<ul style="list-style-type: none"> Test method 2005/83/EC, ANNEXES VII and VIII <table border="1" data-bbox="876 320 1433 555"> <thead> <tr> <th>Frequency (MHz)</th> <th>Limit value (dBμV/m)</th> </tr> </thead> <tbody> <tr> <td>30 – 1000</td> <td>62/52/63 (Broadband QP)</td> </tr> <tr> <td>30 – 1000</td> <td>52/42/53 (Narrowband AVE)</td> </tr> </tbody> </table>	Frequency (MHz)	Limit value (dB μ V/m)	30 – 1000	62/52/63 (Broadband QP)	30 – 1000	52/42/53 (Narrowband AVE)																						
Frequency (MHz)	Limit value (dB μ V/m)																												
30 – 1000	62/52/63 (Broadband QP)																												
30 – 1000	52/42/53 (Narrowband AVE)																												
<p>Conducted disturbances emission test</p>	<ul style="list-style-type: none"> Test method 2005/83/EC, ANNEX X <table border="1" data-bbox="876 672 1433 768"> <thead> <tr> <th>Port</th> <th>Limit level (V)</th> </tr> </thead> <tbody> <tr> <td rowspan="2">24V DC input</td> <td>+150</td> </tr> <tr> <td>-450</td> </tr> </tbody> </table>	Port	Limit level (V)	24V DC input	+150	-450																							
Port	Limit level (V)																												
24V DC input	+150																												
	-450																												
<p>Immunity to transient disturbances conducted along supply lines test</p> <p>Note: The Mini module (2038) and the Mini display (2029) need the Hub module (2021) in order to have the full transient immunity.</p>	<ul style="list-style-type: none"> Test method 2005/83/EC, ANNEX X Performance criterion: <table border="1" data-bbox="991 909 1335 1133"> <thead> <tr> <th>Pulse</th> <th>Criterion</th> </tr> </thead> <tbody> <tr><td>1</td><td>C</td></tr> <tr><td>2a</td><td>B</td></tr> <tr><td>2b</td><td>C</td></tr> <tr><td>3a</td><td>A</td></tr> <tr><td>3b</td><td>A</td></tr> <tr><td>4</td><td>C</td></tr> </tbody> </table> <table border="1" data-bbox="876 1167 1433 1424"> <thead> <tr> <th>Pulse</th> <th>Pulse parameters</th> </tr> </thead> <tbody> <tr> <td>1</td> <td>3/2000 μs, -600 V, 1000 pulses</td> </tr> <tr> <td>2a</td> <td>1/50 μs, +100 V, 1000 pulses</td> </tr> <tr> <td>2b</td> <td>20 V, 220 ms, 2 pulses</td> </tr> <tr> <td>3a</td> <td>5/100 ns, -200 V, 60minutes</td> </tr> <tr> <td>3b</td> <td>5/100 ns, +150 V, 60minutes</td> </tr> <tr> <td>4</td> <td>100 ms -20,5(8,0) V, 20 s - 16,5(12,0) V, 2 pulses</td> </tr> </tbody> </table>	Pulse	Criterion	1	C	2a	B	2b	C	3a	A	3b	A	4	C	Pulse	Pulse parameters	1	3/2000 μ s, -600 V, 1000 pulses	2a	1/50 μ s, +100 V, 1000 pulses	2b	20 V, 220 ms, 2 pulses	3a	5/100 ns, -200 V, 60minutes	3b	5/100 ns, +150 V, 60minutes	4	100 ms -20,5(8,0) V, 20 s - 16,5(12,0) V, 2 pulses
Pulse	Criterion																												
1	C																												
2a	B																												
2b	C																												
3a	A																												
3b	A																												
4	C																												
Pulse	Pulse parameters																												
1	3/2000 μ s, -600 V, 1000 pulses																												
2a	1/50 μ s, +100 V, 1000 pulses																												
2b	20 V, 220 ms, 2 pulses																												
3a	5/100 ns, -200 V, 60minutes																												
3b	5/100 ns, +150 V, 60minutes																												
4	100 ms -20,5(8,0) V, 20 s - 16,5(12,0) V, 2 pulses																												

Epec Oy reserves all rights for improvements without prior notice

<p>Radiated radio-frequency electromagnetic field immunity test</p>	<ul style="list-style-type: none"> • Test method 2005/83/EC, ANNEX IX • Performance criterion: No degradation of 'Immunity-related functions' <table border="1" data-bbox="858 349 1436 680"> <thead> <tr> <th>Specification</th> <th>Frequency Range (MHz)</th> <th>Test level</th> </tr> </thead> <tbody> <tr> <td>Modulation AM80% 1 kHz Sweep step 1%, time/step 3s</td> <td>20-800</td> <td>30 V/m</td> </tr> <tr> <td>PM 577/4600µs</td> <td>800-2000</td> <td>30 V/m</td> </tr> </tbody> </table>	Specification	Frequency Range (MHz)	Test level	Modulation AM80% 1 kHz Sweep step 1%, time/step 3s	20-800	30 V/m	PM 577/4600µs	800-2000	30 V/m
Specification	Frequency Range (MHz)	Test level								
Modulation AM80% 1 kHz Sweep step 1%, time/step 3s	20-800	30 V/m								
PM 577/4600µs	800-2000	30 V/m								
<p>EN 61000-6-3 (2001) Electromagnetic compatibility-generic emission standard part6-3: residential, commercial and light industry</p>										
<p>Radiated disturbance emission test</p> <p>Note: The Color display (2040) needs extra facilities in order to have the limit B covered.</p>	<ul style="list-style-type: none"> • Test method EN 55022 (1994) <table border="1" data-bbox="896 954 1412 1240"> <thead> <tr> <th>Limit</th> <th>Frequency (MHz)</th> <th>Limit value (dBµV/m)</th> </tr> </thead> <tbody> <tr> <td>A</td> <td>30 – 1000</td> <td>40/47 (QP)</td> </tr> <tr> <td>B</td> <td>30 – 1000</td> <td>30/37 (QP)</td> </tr> </tbody> </table>	Limit	Frequency (MHz)	Limit value (dBµV/m)	A	30 – 1000	40/47 (QP)	B	30 – 1000	30/37 (QP)
Limit	Frequency (MHz)	Limit value (dBµV/m)								
A	30 – 1000	40/47 (QP)								
B	30 – 1000	30/37 (QP)								
<p>Conducted disturbance at main ports emission test</p>	<ul style="list-style-type: none"> • Test method EN 55022 (1994) <table border="1" data-bbox="935 1368 1374 1655"> <thead> <tr> <th>Frequency (MHz)</th> <th>Limit value (dBµV)</th> </tr> </thead> <tbody> <tr> <td>0,15 - 30</td> <td>66/56/60 (QP)</td> </tr> <tr> <td>0,15 – 30</td> <td>56/46/50 (AVE)</td> </tr> </tbody> </table>	Frequency (MHz)	Limit value (dBµV)	0,15 - 30	66/56/60 (QP)	0,15 – 30	56/46/50 (AVE)			
Frequency (MHz)	Limit value (dBµV)									
0,15 - 30	66/56/60 (QP)									
0,15 – 30	56/46/50 (AVE)									
<p>EN 61000-6-2 (2005) Electromagnetic compatibility-generic immunity standard part6-2: industrial environment</p>										

Epec Oy reserves all rights for improvements without prior notice

<p>Conducted radio-frequency common mode immunity test</p>	<ul style="list-style-type: none"> • Test method EN 61000-4-6 (1996) • Performance criterion A <table border="1" data-bbox="858 322 1433 566"> <thead> <tr> <th>Specification</th> <th>Port</th> <th>Test level</th> </tr> </thead> <tbody> <tr> <td rowspan="2">Frequency range 0,150-80 MHz Modulation AM80% 1 kHz Sweep step 1%, time/step 3 s</td> <td>DC input port</td> <td>10 Vemf</td> </tr> <tr> <td>Signal ports</td> <td>10 Vemf</td> </tr> </tbody> </table>	Specification	Port	Test level	Frequency range 0,150-80 MHz Modulation AM80% 1 kHz Sweep step 1%, time/step 3 s	DC input port	10 Vemf	Signal ports	10 Vemf	
Specification	Port	Test level								
Frequency range 0,150-80 MHz Modulation AM80% 1 kHz Sweep step 1%, time/step 3 s	DC input port	10 Vemf								
	Signal ports	10 Vemf								
<p>Radiated radio-frequency electromagnetic field immunity test</p>	<ul style="list-style-type: none"> • Test method EN 61000-4-3 • Performance criterion A <table border="1" data-bbox="858 723 1433 1010"> <thead> <tr> <th>Specification</th> <th>Range (MHz)</th> <th>Test level</th> </tr> </thead> <tbody> <tr> <td rowspan="2">Frequency range 80-2700 MHz Modulation AM80% 1 kHz Sweep step 1%, time/step 3 s</td> <td>80-1000</td> <td>20 V/m</td> </tr> <tr> <td>1000-2700</td> <td>3 V/m</td> </tr> </tbody> </table>	Specification	Range (MHz)	Test level	Frequency range 80-2700 MHz Modulation AM80% 1 kHz Sweep step 1%, time/step 3 s	80-1000	20 V/m	1000-2700	3 V/m	
Specification	Range (MHz)	Test level								
Frequency range 80-2700 MHz Modulation AM80% 1 kHz Sweep step 1%, time/step 3 s	80-1000	20 V/m								
	1000-2700	3 V/m								
<p>Electrical fast transient (EFT/B) immunity test</p>	<ul style="list-style-type: none"> • Test method EN 61000-4-4 (1995) • Performance criterion B <table border="1" data-bbox="858 1133 1433 1346"> <thead> <tr> <th>Test pulse</th> <th>Port</th> <th>Test level</th> </tr> </thead> <tbody> <tr> <td rowspan="2">5(Tr)/50(Th) ns, repetition frequency 5 kHz, duration 1 minute</td> <td>DC input port</td> <td>± 2,0 kVp</td> </tr> <tr> <td>Signal ports</td> <td>± 2,0 kVp</td> </tr> </tbody> </table>	Test pulse	Port	Test level	5(Tr)/50(Th) ns, repetition frequency 5 kHz, duration 1 minute	DC input port	± 2,0 kVp	Signal ports	± 2,0 kVp	
Test pulse	Port	Test level								
5(Tr)/50(Th) ns, repetition frequency 5 kHz, duration 1 minute	DC input port	± 2,0 kVp								
	Signal ports	± 2,0 kVp								
<p>CFR 47 Part 15, Subpart B, Class A and B Code of federal regulations (cfr) title 47 telecommunication, part15 radio frequency devices, subpart b unintentional radiators Class a intended for use in industrial/commercial environments Class b intended for use in residential/small office environments</p>										
<p>Radiated emissions</p> <p>Note: The Color display (2040) needs extra facilities in order to have the class B covered.</p>	<ul style="list-style-type: none"> • Test method ANSI C63.4 and EN55022 <table border="1" data-bbox="895 1599 1410 1888"> <thead> <tr> <th>Class</th> <th>Frequency (MHz)</th> <th>Limit value (dBμV)</th> </tr> </thead> <tbody> <tr> <td>A</td> <td>30 – 1000</td> <td>40/47 (QP)</td> </tr> <tr> <td>B</td> <td>30 – 1000</td> <td>30/37 (QP)</td> </tr> </tbody> </table>	Class	Frequency (MHz)	Limit value (dB μ V)	A	30 – 1000	40/47 (QP)	B	30 – 1000	30/37 (QP)
Class	Frequency (MHz)	Limit value (dB μ V)								
A	30 – 1000	40/47 (QP)								
B	30 – 1000	30/37 (QP)								

Epec Oy reserves all rights for improvements without prior notice

CLASSIFICATION OF PERFORMANCE CRITERION

- A: All functions of a device/system perform as designed during and after exposure to disturbance.
- B: All functions of a device/system perform as designed during and after exposure to disturbance. However, one or more of them can go beyond specified tolerance. All functions return automatically to within normal limits after exposure is removed. Memory functions shall remain class A.
- C: One or more functions of a device/system do not perform as designed during exposure but return automatically to normal operation after exposure is removed.
- D: One or more functions of a device/system do not perform as designed during exposure and do not return to normal operation until exposure is removed and a device/system is reset by simple "operator/use" action.
- E: One or more functions of a device/system do not perform as designed during exposure and cannot be returned to operation without repairing the device/system.

6.3 Environmental Tests

The following environmental tests have been performed to Epec 4G modules:

Temperature			
Test	Temperature	Duration/Exposure time	Remarks
Cold IEC 60068-2-1, Test Ab	-45 °C	16 h	-
Dry heat IEC 60068-2-2, Test Bb	70 °C	16 h	-
Damp heat cycling IEC 60068-2-30, Test Db	+25 °C/+55 °C		<ul style="list-style-type: none"> • rel. humidity >90% • six test cycles
Change of temperature IEC 60068-2-14, Test Na	-50 °C/+60 °C	3 h	<ul style="list-style-type: none"> • change time between extreme temperatures 1-2 min • 5 test cycles
Change of temperature IEC 60068-2-14, Test Nb	-40 °C/+70 °C	3 h	<ul style="list-style-type: none"> • change of temperature 10 °C/min • 2 test cycles
Mechanical resistance			
Test	Duration and direction		Remark
Shock/Bump test IEC 60068-2-27, and -29, Tests Ea and Eb	<ul style="list-style-type: none"> • pulse duration 6 ms • 500 impulses in every six directions 		<ul style="list-style-type: none"> • half sine pulse shape • peak acceleration 500 m/s²
Vibration, random IEC 60068-2-64, Test Fh	<ul style="list-style-type: none"> • test duration 60 min in every three test direction 		<ul style="list-style-type: none"> • ASD-level 0,5 m²/s³, 10 ... 200 Hz • ASD-level 1,0 m²/s³, 200 ... 500 Hz • total spectral acceleration 3,54 grms

Epec Oy reserves all rights for improvements without prior notice

Free fall, IEC 60068-2-32, Test Ed	<ul style="list-style-type: none">• one fall / direction on each surface and corner	<ul style="list-style-type: none">• fall height 100 cm	
Corrosion			
Test	Temperature	Duration	Concentration
Salt spray test ISO 9227	+35 °C	24 h	50 g/l, NaCl

Epec Oy reserves all rights for improvements without prior notice

7 HOUSING

- Closed light cast aluminium housing
- Powder-painted, hexavalent chromium free passivation for aluminium
- Puncture hole fastening

7.1 Mounting

- 2 pieces of M6 screws to DIN 912
- If a separate Epec module shock protection cover is mounted, it is recommended to use Epec fastening bolts which are delivered with the cover
- Mounting position horizontal or vertical to allow water etc. flowing away from connectors:

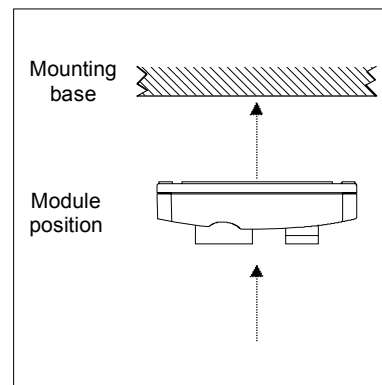
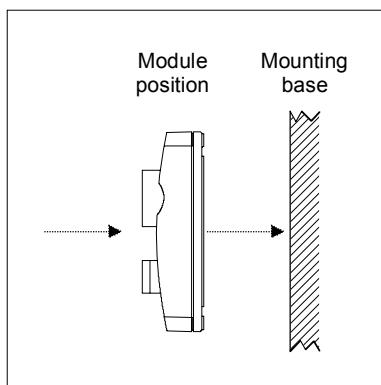

- See the General Mounting and Cabling Instructions for Epec Modules for more detailed information about the module mounting

Epec Oy reserves all rights for improvements without prior notice

7.2 Unit Dimensions

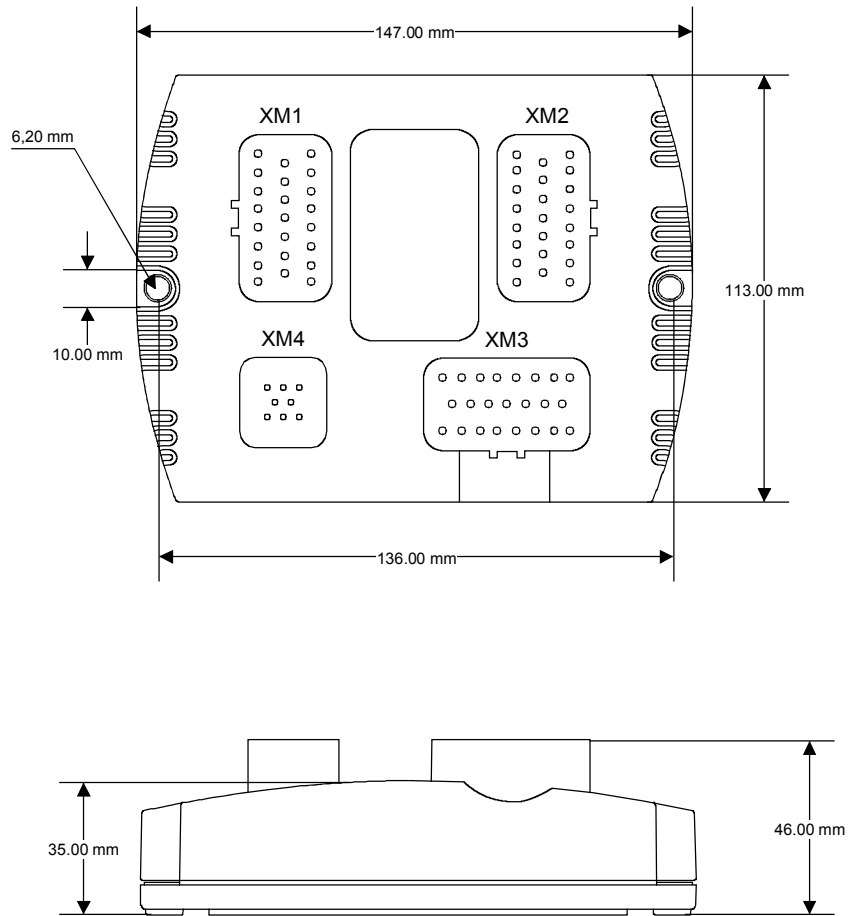

Scale 1:2

Epec Oy reserves all rights for improvements without prior notice

8 ADDITIONAL DOCUMENTS

For more information on Epec control system products, assembly and programming please refer to the following documents:

Document ID	Document name	Document description
MAN000101	Mounting Instructions	General mounting and cabling instructions for Epec modules
MAN000276	CoDeSys 2.3	Programming instructions for CoDeSys 2.3 environment (Note 1)
MAN000275	CoDeSys 2.1	Programming instructions for CoDeSys 2.1 environment
MAN000280	Hardware Library manual	Instructions for programmers using Hardware Library
MAN000285	CANopen Library manual	Instructions for programmers using CANopen Library

Note 1: CoDeSys 2.3 documentation is supplied within target files (for example library files and manuals).

Epec Oy reserves all rights for improvements without prior notice